



LEHIGH
UNIVERSITY

P.C. Rossin College
of Engineering and
Applied Science

MATERIALS SCIENCE & ENGINEERING

UNDERGRADUATE HANDBOOK



Table of Contents

Introduction.....	1
--------------------------	----------

A. Academics

1. The undergraduate program in Materials Science & Engineering	
• Required courses for the B.S. degree	3
• Electives	7
o Engineering Science Electives	9
o Approved Electives	12
• Co-op program and other options	16
2. Minors for Materials Majors	
• Minors for students majoring in Materials	19
• Minor in Nanotechnology	19
• Minor in Polymer Science..... ?	?
• General rules for Minors	22
• Minor(s) Requirements	
<i>Minor in Materials (for students in other disciplines)</i>	21
3. The Materials program for students in the IBE (Integrated Business and Engineering) program	28
5. Integrated Degree – Engineering, Arts & Sciences (IDEAS)	33
6. Prerequisites and the waiving of prerequisites	35
7. Undergraduate Student Overload Policy	36

B. Other

1. Department Awards	39
2. The Student Materials Society	40
3. The Lehigh Microscopy School (in June each year)	41

C. Some words of advice from the faculty “in loco parentis”

1. Choosing HSS courses	43
2. Choosing Electives	43
3. Troubles.....	44

Introduction

The aim of this handbook is to provide students of the Materials Science & Engineering Department with a source of information specific to our Department. We hope it will help you during your time with us.

Lehigh University as a whole has two publications which represent the primary authorities for matters pertaining to students. These are:

1. The Lehigh University Course Catalog –
<http://www1.lehigh.edu/academics/catalog>
2. The Lehigh University Student Handbook –
<http://studentaffairs.lehigh.edu/handbook>

This Materials Science & Engineering Handbook doesn't replace nor supersede these Lehigh University authorities for students. Where this handbook is in disagreement with them, they should be taken as correct. However, our department handbook offers suggestions and detail above and beyond those publications.

Note that, generally speaking, the academic rules that apply are those in the Catalog when you entered Lehigh. If rules change while you are in a program, you may have a choice of going by the old rules (the ones when you started) or going by the new rules. Rules governing non-academic aspects of student life generally come into effect immediately and there will be no option to continue by old rules.

A. Academics

B.S. in Materials Science and Engineering

The program for the **B.S. in Materials Science & Engineering** consists of the common first year for engineering students followed by the program of courses listed for each undergraduate year below.

Class of 2023

CURRICULUM	
Fall Fresh	15 credits: 3 ENGL 1 Critical Reading & Composition 4 MATH 21 Calculus I 2 ENGR 5 Intro to Engineering Practice 4 CHEM 30 Intro to Chemical Principles 2 ENGR 10 Applied Engr. Computer Methods
Spring Fresh	16 credits: 3 ENGL 2 Research & Argument 4 MATH 22 Calculus II 4 HSS 1 (out of 4) or ECO 1 4 PHYS 11 Introductory Physics I 1 PHYS 12 Introductory Physical Laboratory
Fall Soph.	18 credits: 4 MATH 23 Calculus III 4 PHYS 21 Introductory Physics II 1 PHYS 22 Introductory Physics Laboratory II 4 HSS 1 (out of 4) or ECO 1 2 MAT 10 Materials Laboratory 3 MAT 33 Engr. Materials & Processes
Spring Soph.	16 credits: 4 MAT 203 Materials Structure at the Nanoscale 3 MAT 205 Thermo of Macro/Nanoscale Matls. 3 MAT 204 Proc. & Prop. of Polymeric Matls. 3 MAT 218 Mech. Behavior of Macro/Nano Matls. 3 HSS 2 (out of 4)
Fall Junior	17 credits: 3 MAT 20 Computational Methods in Mat. Sci 3 MAT 216 Diffusion & Phase Trans. 2 MAT 101 Professional Development 3 MATH 205 Linear Methods 3 MECH 3 Fund. Of Engr. Mechanics 3 Free Elective 1
Spring Junior	18 credits: 3 MAT 211 Capstone Design Project #1 3 MAT 201 Physical Properties of Materials 3 MAT 206 Proc. & Prop. of Metals 3 MAT 214 Proc. & Prop. of Ceramic Matls. 3 Eng. Sci. Elective 1 3 Free Elective 2
Fall Senior	15 credits: 2 MAT 212 Capstone Design Project #2 3 MAT 252 Electronic Properties of Matls 3 Approved Elective 3 Eng. Sci. Elective 2 4 HSS 3 (out of 4)
Spring Senior	17 credits: 3 MAT 268 Failure Analysis Reports 3 CHE 280 Unit Operations Survey 3 ECE 83 Intro to Electrical Engineering 1 ECE 162 Electrical Laboratory 4 HSS 4 (out of 4) 3 Free Elective 3
TOTAL: 132 credits	

Class of 2024, 2025, 2026

CURRICULUM	
Fall Fresh	15 credits: 3 ENGL 1 Critical Reading & Composition 4 MATH 21 Calculus I 2 ENGR 5 Intro to Engineering Practice 4 CHEM 30 Intro to Chemical Principles 2 ENGR 10 Applied Engr. Computer Methods
Spring Fresh	16 credits: 3 ENGL 2 Research & Argument 4 MATH 22 Calculus II 4 HSS 1 (out of 4) or ECO 1 4 PHYS 11 Introductory Physics I 1 PHYS 12 Introductory Physical Laboratory
Fall Soph.	18 credits: 4 MATH 23 Calculus III 4 PHYS 21 Introductory Physics II 1 PHYS 22 Introductory Physics Laboratory II 3 Free Elective 3 MAT 10 Materials Laboratory 3 MAT 33 Engr. Materials & Processes
Spring Soph.	15 credits: 3 MAT 203 Materials Structure at the Nanoscale 3 MAT 205 Thermo of Macro/Nanoscale Matls. 3 MAT 204 Proc. & Prop. of Polymeric Matls. 3 MAT 218 Mech. Behavior of Macro/Nano Matls. 3 HSS 2 (out of 4)
Fall Junior	18 credits: 3 MAT 20 Computational Methods in Mat. Sci. 3 MAT 216 Diffusion & Phase Trans. 2 MAT 101 Professional Development 3 MATH 205 Linear Methods 3 MECH 3 Fund. Of Engr. Mechanics 4 HSS 1 (out of 4) or ECO 1
Spring Junior	18 credits: 3 MAT 211 Capstone Design Project #1 3 MAT 201 Physical Properties of Materials 3 MAT 206 Proc. & Prop. of Metals 3 MAT 214 Proc. & Prop. of Ceramic Matls. 3 Engineering Science Elective 3 Free Elective
Fall Senior	15 credits: 2 MAT 212 Capstone Design Project #2 3 MAT 252 Electronic Properties of Matls. 3 Approved Elective 3 Engineering Science Elective 4 HSS 3 (out of 4)
Spring Senior	17 credits: 3 MAT 268 Failure Analysis Reports 3 CHE 280 Unit Operations Survey 3 ECE 83 Intro to Electrical Engineering 1 ECE 162 Electrical Laboratory 4 HSS 4 (out of 4) 3 Free Elective 3

TOTAL: 132 credits

B.S. in Materials Science & Engineering

The list of courses required for a B.S. in Materials Science & Engineering is given on the previous pages. On the next page is a chart that shows, in diagrammatic form, the structure of the program.

Each horizontal row of courses on the chart represents a semester of the standard program. For example, the third row down on the chart (MATH 23, PHYS 21, PHYS 22, MAT 33, MAT 10, and ECO 1) gives the courses that most students will take in the fall of the sophomore year. Students with AP credit may be ahead of this standard program and others may be behind.

On the chart, lines represent prerequisite relationships. Where there is a solid line with an arrowhead, the course at the start of the line must be completed (with a C- or higher) before the course at the arrowhead can be taken. Where an arrow has a dotted line, the prerequisite course may be taken concurrently with the course for which it is a prerequisite. These prerequisite relationships given on the chart are for guidance only. The catalog is the official source of information regarding prerequisites.

Many of the elective courses also have prerequisites. These are not shown on the chart.

Program Requirements

Students must achieve a grade of C- or better in all required courses

A student must obtain a 2.0 average in the “major courses” to graduate in Engineering. “Major courses” for Materials Science and Engineering consist of all MAT courses, Capstone courses, and the MAT approved elective.

Important Note:

STUDENTS SHOULD STRIVE TO STAY ON SCHEDULE ACCORDING TO THE PROGRAM STRUCTURE CHART. Most of the materials science courses are given only once a year. That is to say they are given either only in the fall or only in the spring. This means that if you get out of step with the standard sequence, you may have trouble completing the program on time, particularly because of the very tight linking of prerequisites.

Undergraduate Program - Materials Science and Engineering (2023-2024)

(Since all MAT courses, except MAT 33, are given once a year, it is important to follow the schedule below.)

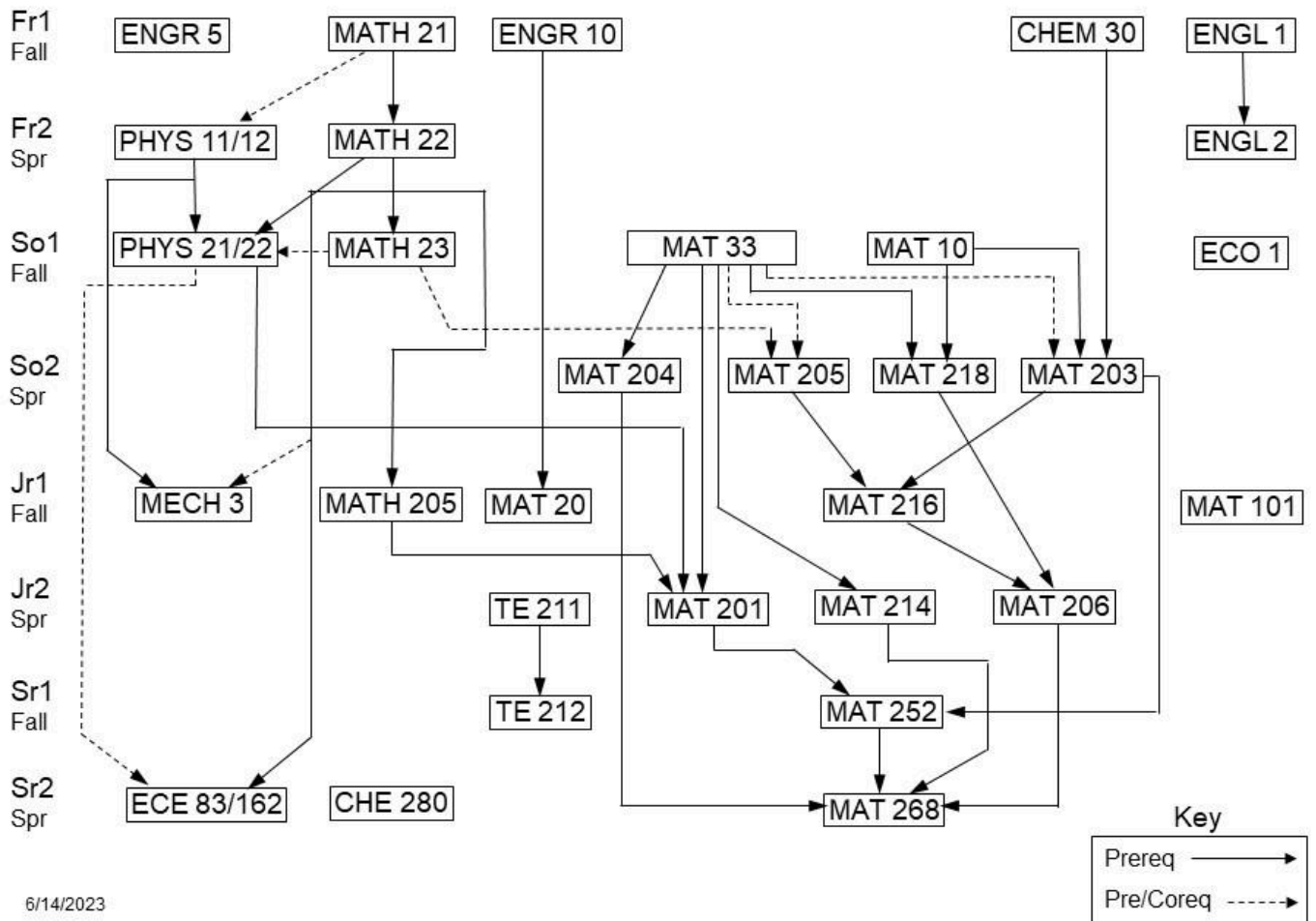

6/14/2023

Electives

Materials Science and Engineering includes a number of elective courses. The aim of including such courses is to allow you to tailor the program to reflect your interests. There are several types of electives. Details are given below.

Engineering Science Electives (TWO 3-credit courses)

These two courses are closely related to the core of the materials program. The idea is, although these are part of the materials program, they give you the opportunity to develop specialization in an area of interest to you. For example, you may want to learn more about polymer materials than the required courses give; then you would take engineering science elective courses in this area. There is a list of courses from which the engineering science electives may be chosen on the following pages.

Approved Elective (ONE 3-credit course)

This is a course that contributes to your materials education but in a less direct way than the required courses or the engineering science elective courses. It is a way of providing increased breadth in your technical education. A list of courses from which you may choose is given on the following pages.

Free electives (THREE 3-credit courses)

To satisfy this requirement, you must take 9 credit hours in any department of your choice that Lehigh offers.

Humanities/Social Sciences (HSS)

In addition to the above courses, students in Materials Science & Engineering (like all engineering students at Lehigh) must take a set of courses in the humanities and social sciences. This is known informally as the HSS requirement. The rules governing the HSS requirement are given in the catalog under the heading, "P.C. Rossin College of Engineering and Applied Science". You should study these rules and make sure to plan your HSS courses to meet them.

A minimum of 4 multi-credit courses and a minimum of 13 credits in courses designated as **HU** (humanities) or **SS** (social science), with the following restrictions:

1. **Depth:** At least 8 credits must be in a common discipline and from the same department or program. At least three of these credits must be at the 100-level or above, or at the intermediate level or above for a single modern foreign language.
2. **Breadth:** At least 3 credits in a discipline different from, and not cross-listed with, the discipline employed to satisfy the depth requirement.
3. At least 3 credits must be designated as HU.
4. None of the courses used for HSS can be taken Pass/Fail.

5. None of the courses can be a 1 credit course.

A course which is eligible to count as a social sciences course for HSS has **(SS)** at the end of the corresponding entry in the catalog. A course which is eligible to count as a humanities course for HSS has **(HU)** at the end of the corresponding entry in the catalog. A course that does not have such an entry cannot be counted towards HSS.

The only exception to this rule is Law 101 which is accepted as meeting HSS requirements.

Engineering Science Electives

MAT 028	Silicon, Steel, or Styrofoam? Designing with Materials
MAT 309	Composite Materials
MAT 311	Introduction to Biomaterials
MAT 312	Fundamentals of Corrosion
MAT 314	Metal Forming Processes
MAT 315	Physical Properties of Structural and Electronic Ceramics
MAT 316	Optical Properties of Materials
MAT 317	Imperfections in Crystals
MAT 319	Polymer Characterization and Analysis
MAT 320	Analytical Methods in Materials Science
MAT 324	(BioE. 324) Intro to Organic Biomaterials
MAT 325	(BioE. 325) Inorganic Biomaterials
MAT 326	(BioE. 326) Biomimetic & Bio-enabled Materials
MAT 327	Industrial Project
MAT 329	Industrial Project
MAT 333	(EES 337, Chm 337) Crystallography and Diffraction
MAT 334	(ChE. 334) Electron Microscopy and Microanalysis
MAT 340	Research Techniques
MAT 341	Undergraduate Research
MAT 342	Inorganic Glasses
MAT 345	Additive Manufacturing and Powder Metallurgy
MAT 346	Physical Metallurgy of Welding
MAT 350	Effective Communication: Proposals, Figures, Papers, and Presentations
MAT 355	Materials for Nanotechnology
MAT 356	Strategies for Nanocharacterization
MAT 359	Thin Film Deposition, Processing, and Characterization
MAT 363	Computational Methods in Science and Engineering
MAT 386	Polymer Nanocomposites
MAT 388	Polymer Characterization
MAT 393	(ChE. 393, Chm 393) Physical Polymer Science
BioE. 324	Intro to Organic Biomaterials
BioE. 325	Inorganic Biomaterials
BioE. 326	Biomimetic & Bio-enabled Materials
BioE. 395	Introduction to Biomaterials
CHE. 031	Material and Energy Balances of Chemical Processes
CHE. 044	Fluid Mechanics
CHE. 210	Chemical Engineering Thermodynamics
CHE. 394	(Chm 394) Organic Polymer Science I
CHM 031	Chemical Equilibria in Aqueous Systems

CHM 110 Organic Chemistry I

Engineering Science Electives (Continued)

CHM 111 Organic Chemistry Laboratory I
CHM 112 Organic Chemistry II
CHM 113 Organic Chemistry Laboratory II
CEE 121 Mechanics of Fluids
CEE 159 Structural Analysis
CEE 259 Structural Analysis II
CSE 017 Structured Programming and Data Structures
CSE 252 Computers, the Internet and Society
ECE 108 Signals and Systems
ECE 123 Electronic Circuits
ECE 125 Circuits and Systems
ECE 126 Fundamentals of Semiconductor Devices
ECE 202 Introduction to Electromagnetics
ECE 203 Introduction to Electromagnetic Waves
ECE 212 Control Theory
ECE 337 Micro & Nano Fabrication
ECE 342 Communication Theory
ECE 343 Digital Signal Processing
ECE 351 Microelectronics Technology
ISE 121 Applied Engineering Statistics
ISE 131 Work Systems and Facilities Planning
ISE 168 Production Analysis
ISE 215 Fundamentals of Modern Manufacturing
ISE 220 Introduction to Operations Research
ISE 224 Information Systems Analysis and Design
ISE 226 Engineering Economy and Decision Analysis
ISE 316 Advanced Operations Research Techniques
ISE 319 Facilities Planning and Materials Handling
ISE 324 Industrial Automation and Robotics
ISE 332 Product Quality
ISE 334 Organizational Planning & Control
ISE 340 Production Engineering
ISE 344 Metal Machining Analysis
ME 010 Graphics for Engineering Design
ME 104 Thermodynamics I
ME 215 Engineering Reliability

ME 240 Manufacturing
ME 231 Fluid Mechanics

Engineering Science Electives (Continued)

ME 242 Mechanical Engineering Systems
ME 255 Introduction to Aerospace Engineering
ME 321 Introduction to Heat Transfer
ME 331 Advanced Fluid Mechanics
ME 343 Control Systems
ME 348 Computer-Aided Design
Mech 012 Strength of Materials
Mech 102 Dynamics
Mech 103 Principles of Mechanics
Mech 302 Advanced Dynamics
Mech 305 Advanced Mechanics of Materials
Mech 307 Mechanics of Continua
Mech 313 Fracture Mechanics

Approved Electives

MAT 028	Silicon, Steel, or Styrofoam? Designing with Materials
MAT 107	Special Topics in Materials
MAT 311	Introduction to Biomaterials
MAT 309	Composite Materials
MAT 315	Physical Properties of Structural and Electronic Ceramics
MAT 316	Optical Properties of Materials
MAT 319	Polymer Characterization and Analysis
MAT 320	Analytical Methods in Materials Science
MAT 324	Intro to Organic Biomaterials
MAT 325	(BioE. 325) Inorganic Biomaterials
MAT 326	(BioE. 326) Biomimetic & Bio-enabled Materials
MAT 327	Industrial Project
MAT 329	Industrial Project
MAT 340	Research Techniques
MAT 341	Undergraduate Research
MAT 342	Inorganic Glasses
MAT 345	Additive Manufacturing and Powder Metallurgy
MAT 350	Effective Communication: Proposals, Figures, Papers, and Presentations
MAT 355	Materials for Nanotechnology
MAT 356	Strategies for Nanocharacterization
MAT 359	Thin Film Deposition, Processing, and Characterization
MAT 363	Computational Methods in Science and Engineering
MAT 386	Polymer Nanocomposites
MAT 388	Polymer Characterization
ACCT 108	Fundamentals of Accounting
ACCT 151	Introduction to Financial Accounting
ACCT 152	Introduction to Managerial Accounting
BIOE 257	Biomechanics and Biomaterials
BIOE 325	Inorganic Biomaterials
BIOE 326	Biomimetic & Bio-enabled Materials
BIOE 395	Introduction to Biomaterials
Bus 127	Information Analysis and Financial Decision Making
CHE. 031	Material and Energy Balances of Chemical Processes
CHE. 044	Fluid Mechanics
CHE. 151	Introduction to Heat Transfer
CHE. 201	Methods of Analysis in Chemical Engineering
CHE. 386	Process Control
CHE. 394	(Chm 394) Organic Polymer Science I

CHM. 031 Chemical Equilibria in Aqueous Systems

**Approved Electives
(Continued)**

CHM. 110	Organic Chemistry I
CHM. 111	Organic Chemistry Laboratory I
CHM. 112	Organic Chemistry II
CHM. 113	Organic Chemistry Laboratory II
CHM. 388	Polymer Synthesis and Characterization Laboratory
CHM. 392	Introduction to Polymer Science
CHM. 394	Organic Polymer Science
CEE 121	Mechanics of Fluids
CSC 017	Structured Programming and Data Structures
ECE 126	Fundamentals of Semiconductor Devices
ECE 202	Introduction to Electromagnetics
ECE 203	Introduction to Electromagnetic Waves
ECE 337	Micro & Nano Fabrication
ECE 351	Microelectronics Technology
EES 316	Hydrogeology
EES 320	Flood Hydrology and Hydraulics
EES 323	Environmental Groundwater Hydrology
EES 327	Surface Water Quality Modeling
EES 334	Petrology of the Crust and Mantle
EES 341	Field Geology
EES 357	Paleoecology and Landscape History
EES 379	Environmental Case Studies
EES 393	Supervised Research in Earth and Environmental Sciences
ENTP 195	Intro to Systematic Creativity Technique
ISE 121	Applied Engineering Statistics
ISE 131	Work Systems and Facilities Planning
ISE 168	Production Analysis
ISE 215	Fundamentals of Modern Manufacturing
ISE 220	Introduction to Operations Research
ISE 224	Information Systems Analysis and Design
ISE 226	Engineering Economy and Decision Analysis
ISE 316	Advanced Operations Research Techniques
ISE 319	Facilities Planning and Materials Handling
ISE 324	Industrial Automation and Robotics
ISE 332	Product Quality
ISE 334	Organizational Planning & Control
ISE 340	Production Engineering

JOUR 311 Science and Technical Writing

**Approved Electives
(Continued)**

JOUR 312 Advanced Science Writing
LAW 101 Introduction to Law
LAW 201 Legal Environment of Business
LAW 202 Business Law
Math 201 Problem Solving
Math 202 Actuarial Exam
Math 207 Introduction to Biomedical Engineering and Mathematical Physiology
Math 208 Complex Variables
Math 230 Numerical Methods
Math 231 Probability and Statistics
Math 234 Fractal Geometry
Math 242 Linear Algebra
Math 243 Algebra
Math 261 Discrete Structures
Math 301 Principles of Analysis I
Math 302 Principles of Analysis II
Math 303 Mathematical Logic
Math 304 Axiomatic Set Theory
Math 307 General topology
Math 309 Theory of Probability
Math 310 Probability and Its Applications
Math 312 Computational Statistics
Math 316 Complex Analysis
Math 320 Ordinary Differential Equations
Math 322 Methods of Applied Analysis
Math 323 Methods of Applied Analysis II
Math 327 Groups and Rings
Math 329 Recursive Functions and the Theory of Computation
Math 334 Mathematical Statistics
Math 338 Regression Analysis
Math 340 Design and Analysis of Algorithms
Math 341 Mathematical Models and Their Formulation
Math 342 Number Theory
Math 350 Special Topics
Math 371 Readings
Math 374 Statistical Project
Math 391 Senior Honors Thesis

Approved Electives (Continued)

Mech 012	Strength of Materials
Mech 305	Advanced Mechanics of Materials
Mech 313	Fracture Mechanics
Phil 128	Philosophy of Science
Phy 201	Modern Astrophysics I
Phy 202	Modern Astrophysics II
Phy 212	Electricity and Magnetism
Phy 213	Electricity and Magnetism
Phy 215	Classical Mechanics
Phy 262	Advanced Physics Laboratory
Phy 273	Research
Phy 281	Basic Physics I
Phy 282	Basic Physics II
Phy 332	High-Energy Astrophysics
Phy 340	Thermal Physics
Phy 342	Relativity and Cosmology
Phy 348	Plasma Physics
Phy 352	Modern Optics
Phy 355	Lasers and Non-linear Optics
Phy 362	Atomic and Molecular Structure
Phy 363	Physics of Solids
Phy 365	Physics of Fluids
Phy 369	Quantum Mechanics
Phy 372	Special Topics in Physics
Phy 380	Introduction to Computational Physics

CO-OP PROGRAM AND OTHER OPTIONS

**** The CO-OP Program is no longer officially recognized by Lehigh, however, should you wish to pursue it you would need to make all arrangements between you and your advisor. ****

Recognizing the field of materials science and engineering may be pursued in either an industrial setting or a research setting. The department offers three elective options to prepare students for these careers: The Co-Op Program, the Industrial Option, and the Research Option.

Co-Op Program:

The department's optional Co-Op program, operated within the College of Engineering and Applied Science, provides opportunities for integration of academic studies with significant periods of engineering practice. For more information, contact the Center for Career and Professional Development at careercenter@lehigh.edu

Fall & Spring First Year	31 credits total, including (4) HSS 1
Fall Sophomore	18 credits: 3 MAT 10 Materials Laboratory 3 MAT 33 Engr. Materials & Processes 4 Math 23 Calculus III 5 Phys. 21, 22 Physics II and Lab 3 Free Elective
Spring Sophomore	15 credits: 3 MAT 203 Materials Structure at the Nanoscale 3 MAT 205 Thermodynamics of Macro/Nanoscale Matls. 3 MAT 218 Mech. Behavior of Macro/Nanoscale Matls. 3 MAT 204 Processing and Properties of Polymeric Matls. 3 HSS #2
Summer	Session 1 (7-Credits): 1 ENGR 130 Engineering Communications 3 Math 205 Linear Methods 3 Mech 3 Fundamentals of Engineering Mechanics Session 2 (8-Credits): 4 HSS #3 4 HSS #4
Fall Junior	Co-op (3-Credits): 3 ENGR 200 Engineering Co-op
Spring Junior	15 credits: 3 MAT 214 Processing and Properties of Ceramic Matls. 3 MAT 201 Physical Properties of Materials 3 MAT 211 Capstone Design Project #1 3 Free Elective

	3 Engineering Science Elective 1
Summer	Co-op (3-Credits): 3 ENGR 200 Engineering Co-op
Fall Senior	16 credits: 3 MAT 20 Computational Methods 2 MAT 101 Professional Development 3 MAT 216 Diffusion & Phase Trans 3 MAT 252 Electronic Properties of Matls. 2 MAT 212 Capstone Design Project #2 3 Approved Elective
Spring Senior	16 credits: 3 MAT 206 Processing and Properties of Metals ¹ 3 MAT 268 Failure Analysis Reports 3 CHE 280 Unit Operations Survey 3 ECE 83 Intro to Electrical Engineering 1 ECE 162 Electrical Laboratory 3 Eng. Sci. Elective 2

TOTAL: 132 credits

Industrial Option:

The Industrial Option introduces students to the work of materials engineers in industry. The emphasis is a team approach to the solution of actual plant problems. The courses are conducted in cooperation with local industries. 20 hours a week are spent at the plant of the cooperating industry on investigations of selected problems. The option is limited to a small group of seniors, selected by the department from those who apply in their sophomore year. Summer employment is provided when possible for those who elect to initiate the program during the summer preceding the senior year.

Research Option:

The Research Option is offered for students interested in research and development. Financial support may be available for students who elect to initiate a research program during the summer preceding their senior year. The option is limited to a small group of students, selected by the department from those who apply in their sophomore year.

Industrial Option:

MAT 327	Industrial Project	4
MAT 329	Industrial Project	4

Research Option:

MAT 340	Research Techniques	3
MAT 341	Undergraduate research	3

¹ Will require a waiver for Mat 206 to act as a co-req. for Mat 268.

Minors in the Department of Materials Science & Engineering

The Department of Materials Science & Engineering offers minors for students majoring in other subjects and supports minors for students majoring in the materials program. The Department is enthusiastic in its support of students who wish to broaden their education by taking a minor.

a. Minors for Students Majoring in Materials

Students majoring in Materials Science & Engineering are encouraged to take a minor in another field.

In four cases, where the match between the major and the minor is particularly good, the Department has made specific arrangements with the corresponding departments to establish minors. These are minors in Chemical & Biomolecular Engineering, Industrial & Systems Engineering, Mechanical Engineering, and in Polymer Science & Engineering. Details are given below, see appendices 2, 3, 4 and 5.

Many other minors are possible and encouraged, including minors in other engineering departments (Computer Science, Environmental Engineering) as well as in other colleges. There are about sixty minors available in the College of Arts and Sciences, reflecting a very broad range of interests (ex: Education and Business). In these cases, there is no specific arrangement made for Materials majors. The normal procedure is for the student to make arrangements directly with the department in question. It would be helpful to deposit a copy of the paperwork in the Materials office.

A student who is contemplating the possibility of taking a minor should start by talking to his or her advisor but should also talk to the person responsible for the minor program in the department hosting the minor (normally the associate chair but the departmental secretary will be able to say who it is).

b. Minor in Nanotechnology

Materials for nanotechnology applications have new properties unavailable in bulk materials. The synthesis, processing, and characterization of these materials require a facility with concepts beyond those needed for typical engineering materials. This minor requires 15 credits selected from the lists below.

Required Courses

I Basics of Nanotechnology

MAT 355 Materials for Nanotechnology (3)

II Crystallography and Band Theory

Choose one of the following three courses:

Course		Pre-requisites
MAT 252	Electronic Properties of Materials (3)	MAT 201 and MAT 203
PHY 363	Physics of Solids (3)	CHM 341 or PHY 31 or MAT 316 and PHY 340
CHM 341	Molecular Structure, Bonding & Dynamics (4)	PHY 11 or 13, MATH 22 or MATH 096 or MATH 32, CHM 31 or CHM 41

Elective Courses

Elective courses are to be selected from the list below. New courses will be added to this list as they are created.

Course		Pre-req. / Co-req.
MAT 205	Thermodynamics of Macro/Nanoscale Materials (3)	MAT 33 and Math 23 (Co-req.)
MAT 316	Optical Properties of Materials (3)	MAT 33
MAT 334	Electron Microscopy and Microanalysis (4)	
MAT 345	Additive Manufacturing and Powder Metallurgy (3)	MAT 206
MAT 356	Strategies for Nanocharacterization (3)	
MAT 359	Thin Film Deposition, Processing and Characterization (3)	Junior/Senior year only (Offered every other year)
CHE 391	Colloid and Surface Chemistry (3)	Permission of Instructor
CHE 413	Heterogeneous Catalysis & Surface Characterization	
CHM 488	Advanced Topics in Physical Chemistry	
ECE 126	Fundamentals for Semiconductor Devices (3)	ECE 81
ECE 325	Semiconductor Lasers I (3)	ECE 203
ECE 337	Intro. To Micro- and Nanofabrication (3)	(MAT 33 and MATH 231) or ECE 351
ECE 338	Quantum Electronics (3)	ECE 203
ECE 351	Microelectronics Technology (3)	ECE 126
PHY 369	Quantum Mechanics I (3)	PHY 31, PHY 215, MATH 205
PHY 372	Special Topics in Physics	

Additional requirement: Since the aim of this minor is to provide an interdisciplinary program in nanotechnology, students must take at least **one** course outside their home department. Courses of individual study (including laboratory projects) on relevant topics, in any appropriate department, will also be accepted as electives for the minor, with the approval of the advisor.

c. Minor in Materials (for students in other disciplines)

To obtain a minor in Materials Science & Engineering, a student must complete one required course (MAT 33, 3-credits) and (4) other 3-credit courses, for a total of 15 credit hours. See requirements for a minor in materials Science and Engineering for more details.

Some General Rules Which Apply To All Minors

1. The minimum number of credits for a minor is 15. However, many minors may require more in practice, because of the specific requirements of the program.
2. It may be possible for a course to contribute to both the requirements of the major and to the requirements for the minor.
 - a. At most one required course of the major may contribute to the minor.
 - b. Approved electives, engineering electives, technical electives etc. may be used to take courses which contribute to the minor, provided the courses on the corresponding list for the major.
 - c. Free electives (and, in some cases, courses to meet the HSS requirement) can be used as courses needed for the minor.
3. Courses that are cross listed between the departments of the major and the minor may not be taken as contributing to the requirements of the minor, unless a specific exception is made in the program.
4. A 2.0 minimum grade-point average is required for courses in the minor. Because of this requirement, no course in the minor program may be taken with Pass/Fail grading.
5. It is the responsibility of the student desiring a minor to complete a formal registration for the minor in the department, division, or program where it is offered. Officially, this may be done at any time up to the time of registration for the student's final semester. However, it is strongly recommended the registration for the minor be completed as early as possible. Preferably, no later than the beginning of the junior year (some programs may have this as a requirement). The student's minor advisor maintains appropriate records.

Requirements for a Minor in Materials Science and Engineering

Minor in Materials Science and Engineering

To obtain a minor in materials science and engineering a student must complete at least 15 credit hours of materials science and engineering as follows:

REQUIRED COURSE:

MAT 33 Engineering Materials and Processes (3)

ELECTIVES:

MAT 10 and MAT 028 may be used as an elective. The remaining courses to complete the minor may be any 200-level or 300-level courses offered by the Department of Materials Science & Engineering, with the exception of the following courses which are excluded: MAT 268 (Failure Analysis Reports), MAT 327 (Industrial Project), MAT 329 (Industrial Project), MAT 340 (Research Techniques), and MAT 341 (Undergraduate Research).

Requirements for a Minor in Chemical Engineering

ChemE. Minor For Materials Science & Engineering Students

To obtain a minor in Chemical and Biomolecular Engineering within the materials science and engineering undergraduate curriculum, an MS&E Major must complete 5 courses as follows:

REQUIRED COURSES:

ChE. 31	Material and Energy Balances of Chemical Processes (3)
ChE. 44	Fluid Mechanics (3)
ChE. 151	Introduction to Heat Transfer (3)
ChE. 210	Chemical Engineering Thermodynamics (4)
ChE. 211	Chemical Reactor Design (3)

ELECTIVES:

ChE. 201	Methods of Analysis in Chemical Engineering (4)
ChE. 242	Intro. To Process Control and Simulation (3)
ChE. 244	Mass Transfer and Separation Processes (3)
ChE. 321	Biomolecular & Cellular Mechanics (3)
ChE. 341	Biotechnology I (3)
ChE. 342	Biotechnology II (3)
ChE. 391	Colloid and Surface Chemistry (3)
ChE. 392	Introduction to Polymer Science (3)

Note:

Students taking the ChE. minor can replace ChE. 280 with a free elective.

Requirements for a Minor in Manufacturing Systems Offered by the Department of Industrial and Systems Engineering

Minor in Manufacturing Systems Engineering

To obtain a minor in Manufacturing Systems Engineering a student must take at least 16 credit hours. A student must take a required course from each of 4 areas and 2 elective courses from a general list.

REQUIRED COURSES:

Computer Graphics Requirement:

ISE 112 Computer Graphics (1) **or**
ME 10 Graphics for Engineering Design (3) **or**
CEE 010 Engineering/Architectural Graphics and Design (3)

Probability and Statistics Requirement:

Math 231 Probability and Statistics (3) **or**
ISE 328 Engineering Statistics (3) **or**
ISE111 Engineering Probability (3) **and**
ISE 121 Applied Engineering Statistics (3)

Manufacturing Processes:

ISE 215 Fundamentals of Modern Manufacturing (3)
MAT 206 Processing and Properties of Metals (3) **or**
ME 240 Manufacturing (3)

Production Analysis:

ISE 168 Production Analysis (3)

ELECTIVES:

At least 2 elective courses from the following list:

ISE 131 Work Systems and Operations Management (3)
ISE 319 Facilities Planning and Material Handling (3)
ISE 324 Industrial Automation and Robotics (3)
ISE 332 Product Quality (3)
ISE 334 Organizational Planning and Control (3)
ISE 340 Production Engineering (3)
ISE 347 Financial Optimization (3)

Requirements for a Minor in Mechanics of Materials Offered by the Department of Mechanical Engineering and Mechanics

DESCRIPTION:

The minor in Mechanics of Materials provides a view of mechanical strength and behavior of materials based on understanding of a few basic concepts and using simplified material models. Courses selected for the minor emphasize concepts such as superposition of loadings, relation between external loads and internal stresses; factor of safety, safe design based on allowable stress or allowable loads, allowable deformation, and reliability of structures. Courses offer a wide variety of topics including analytical and numerical methods for solving mechanics problems, manufacturing, and polymer processing. The Mechanics of Materials minor requires a minimum of 15 credits, which must be taken from MEM offerings. 2 courses are required and 3 additional electives must be selected. The minor is not available for students having a major in the Department of Mechanical Engineering and Mechanics.

REQUIRED COURSES:

MECH 3 (3)	Fundamentals of Engineering Mechanics
MECH 12 (3)	Strength of Materials

ELECTIVES:

ME 10 (3)	Graphics for Engineering Design
ME 215 (3)	Engineering Reliability
ME 240 (3)	Manufacturing
ME 252 (3)	Mechanical Elements
ME 385 (3)	Polymer Product Manufacturing
MECH 102 (3)	Dynamics
MECH 305 (3)	Advanced Mechanics of Materials
MECH 312 (3)	Finite Element Analysis
MECH 313 (3)	Fracture Mechanics

Notes:

ME 10 is a prerequisite for ME 240.

MECH 102 is a prerequisite for ME 252.

****Interested students should contact the Mechanical Engineering Department****

It would be helpful to deposit a copy of the completed paperwork in the Materials Science & Engineering Department office as well.

Requirements for a Minor in Polymer Science and Engineering

(Polymer manufacture, physical and chemical properties, composite materials, polymer colloids, polymer applications, etc.)

To earn a minor in Polymer Science & Engineering, a student must register for at least 15 credits of coursework distributed as follows:

REQUIRED COURSES:

CHM 110 Organic Chemistry I
CHM 194 Physical Chemistry **or** MAT 33 (for chemistry majors)
MAT 204 Processing and Properties of Polymeric Materials

ELECTIVES: (select two)

MAT/ME 309 Composite Materials – Fall semester – senior year
(Prerequisite: MAT 33, MECH 3, senior standing)

MAT 311 Introduction to Biomaterials – Fall semester

MAT 334 Electron Microscopy and Microanalysis – Fall semester – senior year
(Prerequisite: Permission and senior standing)

ME 385 Polymer Product Manufacturing – Fall Semester
(Prerequisite: Senior level standing in engineering or science)

MAT 386 Polymer Nanocomposites – Fall semester
(Prerequisite: Permission and senior standing)

MAT 388 Polymer Characterization
(Prerequisite: MAT 33 or MAT 204 or MAT 392 or MAT 393 or equivalent)

CHE. 391 Colloid and Surface Chemistry – Spring semester – senior year
(Prerequisite: Permission of the instructor)

CHE. 392 Introduction to Polymer Science – Fall semester – senior year

CHE. 393 Physical Polymer Science – Fall semester – senior year
(Prerequisite: senior standing)

CHM. 394 Organic Polymer Science I – Spring semester – senior year
(Prerequisite: see course catalog)

The IBE Degree and Accreditation

The B.S. Degree in Materials Science & Engineering is an “accredited” degree. This means it is recognized as satisfying one requirement for the Professional Engineering (PE) license. For some careers and some professional activities, it is a requirement to hold the Professional Engineering License. Indeed, in Pennsylvania, you may not have “engineer” in your job title unless you have the PE license.

The Integrated Business & Engineering (IBE) degree is **not** an accredited engineering degree and will not, therefore, serve towards the acquisition of PE status.

Those who elect to take IBE have been and will be explicitly warned the degree will not lead to PE. However, it is possible students will change their minds and wish to get, in addition to the IBE, a regular engineering degree in order to go on to the PE.

In order to obtain an accredited engineering degree, a student would have to complete the set of courses needed for our normal B.S. in Materials Science & Engineering. The courses that are required for the B.S. in Materials Science & Engineering are not included in the IBE degree amount to 23 credits. However, Lehigh has a general rule which states a student may not obtain a second degree with fewer than 30 additional credits.

Therefore, to obtain the accredited degree as well as IBE, a student would have to take courses totaling up to 30 additional credits (23 credits of the materials program courses, not included in IBE, plus additional credits in any courses of the student’s choice).

Curriculum for an IBE Major in Materials Science and Engineering
(As of 6/20)

(PC) = Previously or Concurrently (CO) = Co-requisite: must be taken at the same time

Freshman Year, Fall Semester

Credits	Course	Description	Semester	Prerequisites
3	English 001	Composition & Literature	F,S	
4	Math 21	Calculus I	F,S	
5	Physics 11, 12	Introductory Physics I	F,S	Math 21 (PC)
4	Economics 001	Principles of Economics	F,S	
1	IBE 010	IBE Freshman Seminar	F	IBE Student
17	Semester total			
17	Cumulative credits			

Freshman Year, Spring Semester

Credits	Course	Description	Semester	Prerequisites
3	English 2	Comp. & Lit.	F,S	English 1
4	Math 22	Calculus II	F,S	Math 21
4	Chem 30	Intro. Chemical Principles	F,S	
3	IBE 050	IBE Freshman Workshop	S	IBE 010 or Permission
2	Engineering 010	Engineering Computations	F,S	
16	Semester total			
33	Cumulative credits			

Sophomore Year, Fall Semester

Credits	Course	Description	Semester	Prerequisites
3	MAT 33	Engr. Mat. & Processes	F,S	
3	MAT 10	Materials Lab	F	MAT 33 (PC)
4	Physics 21	Introductory Physics II	F,S	Phys. 11, Math 23 (PC)
1	Physics 22	Physics Lab	F,S	Physics 12, Phys. 21 (CO pref.)
4	Math 23	Calculus III	F,S	Math 22
1	IBE 150	IBE Sophomore Lab	F	IBE status
16	Semester total			
49	Cumulative credits			

Sophomore Year, Spring Semester

Credits	Course	Description	Semester	Prerequisites
3	MAT 203	Struct. & Char. of Materials	S	Chem 30, MAT 33 (PC), MAT 10
3	MAT 205	Thermo & Phase Diagrams	S	MAT 33 (PC), Math 23
3	MAT 218	Mech. Behavior of Materials	F	MAT 33
3	Eco 029	Money & Banking	F,S	Eco 1
3	Acct 151	Intro. Financial Accounting	F,S	Sophomore standing, Engr. 010
3	Free Elective			
18	Semester total			
67	Cumulative credits			

Junior Year, Fall Semester

Credits	Course	Description	Semester	Prerequisites
3	MAT 216	Diffusion & Phase Trans.	F	MAT 203, MAT 205
3	MAT 20	Comp. Meth. In Mat. Sci.	F	Engr. 010
3	Math 231	Prob. & Statistics	F,S	Math 22
3	Acct 152	Intro. Managerial Accounting	F,S	Acct 151
4	Comm. 160* or 130	Public Speaking for IBE	F,S	
1	IBE 250	IBE Junior Lab	F	IBE 150
17	Semester total			
84	Cumulative credits			

* Comm. 160 recommended

Junior Year, Spring Semester

Credits	Course	Description	Semester	Prerequisites
3	MAT 201	Physical Props. of Matls.	S	Phys. 21, MAT 33, Math 205
3	MAT 204 or	Proc. of Polymers	S	204: MAT 33
	MAT 206 or	Proc. of metals	S	206: MAT 216, MAT 218
	MAT 214	Proc. of Ceramics	S	214: MAT 33
	(or MAT 252 in senior year)	Elect. Prop. Mats.	F	252: MAT 201, 203
3	Fin 125	Intro. to Finance	F,S	Eco 029, Acct 151, Math231
3	Mkt 111	Prin. Of Marketing	F,S	Eco 1, Sophomore Standing
3	Math 205	Linear Systems	F,S	Math 23 (PC)
3	IBE 380	IBE Capstone Design I	S	IBE 050
18	Semester total			
102	Cumulative credits			

Senior Year, Fall Semester

Credits	Course	Description	Semester	Prerequisites
3	Mech 3	Elem. Engr. Mechanics	F, S	Phys. 11, Math 22 (PC)
3	Eco 146	App. Microeconomics	F,S	Eco 1, Math 231
3	Law 201	Legal Env. of Business	F,S	Eco 1, Junior standing
3	BIS 111	Prin. Of Marketing	F,S	Engr. 010 (Excel experience)
3	HSS Elective			(Dual degree, see below)
3	IBE 385	IBE Capstone Design II	F	IBE 380
18	Semester total			
120	Cumulative credits			

Senior Year, Spring Semester

Credits	Course	Description	Semester	Prerequisites
3	ChE. 280 (formerly 60)	Unit operations survey	S	
3	ECE 83	Prin. Electrical Engr.	F,S	Math 22, Phys. 21 (PC)
1	ECE 162	Prin. Electrical Engr. Lab	F,S	ECE 81 or ECE 83 (PC)
4	Mgmt. 243	Mgmt. of People & Ops.	F,S	Junior Standing
3	Free Elective			
4	HSS Elective			(Dual degree, see below)
18	Semester total			

In addition to the curriculum above, IBE MS&E majors must fulfill standard IBE requirements including:

- Language proficiency
- Summer internship
- Maintain a GPA of at least 3.25

MS&E Dual Degree Option

Courses required for the BS-MS&E degree not taken by IBE MS&E Majors:

Credits	Course	Description	Semester	Prerequisites
2	MAT 101	Professional Development	F	Junior Standing
9	(Remaining 3 of 4 courses), MAT 204, MAT 206, MAT 214, MAT 252		(see above)	(see above)
3	MAT 268	Failure Analysis Reports	S	MAT 204, 206, 214, 218
3	Approved Elective	See options in catalog		
6	Engr. Sci. Elec.	See options in catalog		
2	Free Elective			
25	Total Credits			

Completing the Dual Degree program with simultaneous BS-IBE and BS-MS&E degrees after the 5th year

1. Take the above “**Courses required for the BSMS&E degree not taken by IBE MS&E Majors**”
2. Complete at least 162 total credits (MS&E degree requires 132 + 30 credits from the “30 credit rule”)
3. Take at least 2 additional credits of ECO as an HSS elective to fulfill the "8 credits in 1 dept." rule (most ECO courses higher level than ECO 001 count as SS)

If a student is planning ahead to receive both degrees after five years, the recommended junior, senior, and 5th year sequence is:

Junior Year, Spring Semester (dual degree)

Credits	Course	Description	Semester	Prerequisites
6	MAT 204 or MAT 206 or MAT 214	Proc. of Polymers Proc. of Metals Proc. of Ceramics	S S S	204: MAT 33 206: MAT 216, MAT 218 214: MAT 33
3	Fin 125	Intro. to Finance	F,S	Eco 029, Acct 151, Math231
3	Mkt 111	Prin. Of Marketing	F,S	Eco 1, Sophomore Standing
3	Math 205	Linear Systems	F,S	Math 23 (PC)
3	IBE 380	IBE Capstone Design I	S	IBE 050

18	Semester total
102	Cumulative credits

4th Year, Fall Semester (dual degree)

Credits	Course	Description	Semester	Prerequisites
3	MAT 20	Comp. Meth. In Mat. Sci.	F	Engr. 010
2	MAT 101	Professional Development	F	Junior Standing
3	Eco 146	App. Microeconomics	F,S	Eco 1, Math 231
4	HSS Elective			(Dual degree, see ECO option)
3	IBE 385	IBE Capstone Design II	F	IBE 380
15	Semester total			
117	Cumulative credits			

4th Year, Spring Semester (dual degree)

Credits	Course	Description	Semester	Prerequisites
3	MAT 201	Phys. Props. Of Matls.	S	Phys. 21, MAT 33, Math 205
3	MAT 204 or	Proc. of Polymers	S	204: MAT 33
	MAT 206 or	Proc. of Metals	S	206: MAT 216, MAT 218
	MAT 214	Proc. of Ceramics	S	214: MAT 33
	(whichever remains)			
4	Mgmt. 243	Mgmt. of People & Ops.	F, S	Junior Standing
4	HSS Elective			(Dual deg., see ECO option)
14	Semester total			
131	Cumulative credits			

5th Year, Fall Semester (dual degree)

Credits	Course	Description	Semester	Prerequisites
3	BIS 111	Intro to Info Systems	F,S	Engr. 010 (Excel experience)
3	MAT 252	Elect. Prop. Mats.	F	MAT 201, 203
3	Law 201	Legal Env. of Business	F,S	Eco 1, Junior standing
4	HSS Elective			
3	Engr. Sci. Elec.	See options in catalog		
16	Semester total			
147	Cumulative credits			

5th Year, Spring Semester (dual degree)

Credits	Course	Description	Semester	Prerequisites
3	ChE. 280 (formerly 60)	Unit operations survey	S	
3	ECE 83	Prin. Electrical Engr.	F,S	Math 22, Phys. 21 (PC)
1	ECE 162	Prin. Electrical Engr. Lab	F,S	ECE 81 or ECE 83 (PC)
3	Approved Elective	See options in catalog		
3	MAT 268	Failure Analysis Reports	S	MAT 204, 206, 214, 218
3	Engr. Sci. Elec.	See options in catalog		
16	Semester total			
163	Cumulative credits			

Integrated Degree – Engineering, Arts & Sciences (IDEAS)

(As of 5/09)

IDEAS is a four-year honors program, resulting in a Bachelor of Science (B.S.) Degree, **Integrated Degree in Engineering, Arts, & Sciences (IDEAS)**, jointly administered by the College of Arts & Sciences and the P.C. Rossin College of Engineering & Applied Science.

Entry Requirements:

1. Admitted students who have expressed interest when applying, will be considered for the IDEAS program; only a limited number of students will be accepted. Students are accepted into this honors program by invitation.
2. To remain in the IDEAS program, students must maintain a 3.25 GPA. At the end of the first year, a student with a GPA below 3.25 is given two semesters to achieve a GPA of 3.25; otherwise the student would be asked to transfer to a regular degree program in arts and sciences or engineering.
3. Students may transfer into the IDEAS program at the end of their first semester or year if space becomes available. A formal application to the program must be filed, and approval must be obtained from the co-directors.
4. Students who are interested in the IDEAS program should contact one of the co-directors at any time prior to or after submitting an application to Lehigh.

The IDEAS program is designed so students who transfer out of the program at the completion of the first year will still be able to complete an arts, science, or engineering degree in four years. The four year IDEAS program doesn't lead to an ABET-accredited engineering degree. It is possible for students to complete a B.S. degree in IDEAS and an ABET-accredited B.S. engineering degree (dual degrees) in one or two additional semesters.

Term-by-Term Sample for the IDEAS Program:

First Year:

Fall

IDEA 11	IDEA Seminar I
Math 21	Calculus I
Physics 11/12	Physics I
Arts & Science	Concentration Course

Spring

IDEA 12	IDEA Seminar II
Math 22	Calculus II
Chem 25 (Chem 30)	Intro Chem Principles
Arts & Science	Concentration Course
Engr.	Major Course

Sophomore Year:

Fall

IDEA 111	IDEA Seminar III
Math 23	Calculus III
Chem 31	Chem. Aqueous Sys
Arts & Science	Concentration Course
Engr.	Concentration Course

Spring

IDEA 112	IDEA Seminar IV
Math 205	Linear Methods
Phys. 21/22	Physics II & Lab
Arts & Science	Concentration Course
Engr.	Concentration Course
Elective	Elective

Junior Year:

Fall

IDEA 150	IDEA Project
Chem 51	Organic Chemistry
Arts & Science	Concentration Course
Engr.	Concentration Course
Engr.	Concentration Course

Spring

Arts & Science	Concentration Course
Arts & Science	Concentration Course
Engr.	Concentration Course
Engr.	Concentration Course
Elective	Elective

Senior Year:

Fall

IDEA 210	IDEA Senior Thesis
Arts & Science	Concentration Course
Engr.	Concentration Course
Engr.	Concentration Course
Elective	Elective

Spring

Arts & Science	Concentration Course
Engr.	Concentration Course
Engr.	Concentration Course
Engr.	Concentration Course
Elective	Elective

Total

136

Notes:

1. Each year, one 3-credit IDEAS core course is required, and an average of one 4-credit elective block course is taken.
2. Each of the 36-credit **Math/Science**, **Arts & Sciences**, and **Engineering** blocks require an average of one 4-credit course per semester plus an additional 4 credits.
3. Engineering major courses are usually 3 credits.

Prerequisites

Lehigh University rules state a grade of D+, D, or D- is a pass but is not “adequate to take any subsequent course which has this course as a prerequisite.” Therefore any student who gets a D, F, or W on a course must take it again if the course is a prerequisite for a required Materials course. Even if a professor temporarily waives the prerequisite, the course must be repeated.

In the Department of Materials Science & Engineering it is the policy that a professor has the right to waive a prerequisite for a course they teach. In particular, a student with a ‘D’ in a course may be allowed, at the discretion of the professor, to take a course for which the ‘D’ course is a prerequisite. Normally, in order to waive the prerequisite, the professor will require the student to demonstrate competence, by taking a test (prior to starting the course) or by meeting some other conditions set by the professor. If a student negotiates conditions to be met for the waiver of a prerequisite, a written record of what is agreed must be left in the Department office. The Department will accept waivers of prerequisites only when the student file contains a statement indicating the professor’s conditions have been met.

Summary

A student’s advisor may not waive a prerequisite.

The professor of the course may waive a prerequisite at his or her discretion. This waiver must be confirmed in writing (email acceptable) and a paper copy placed in the student file.

If conditions are imposed on the waiver (e.g. I will give you a test on this material.), the conditions must be confirmed in writing (email acceptable) and a paper copy placed in the student file at the time the conditions are set.

The courses outside our department in which a C-minus or higher grade must be attained are the following: CHEM 30, PHYS 11/12, PHYS 21/22, MATH 21, MATH 22, MATH 23, MATH 205, and MECH 3.

Undergraduate Student Overload Policy **for students planning on taking 19 or more credits** (Current as of)

The normal course load for a Lehigh undergraduate is 12 to 18 credits. Full-time status requires at least 12 credits. Students are urged to avoid part-time status without careful consideration of the consequences, which may include loss of eligibility for financial aid, participation in sports or other extracurricular activities, veterans' or other benefits, university housing, and certain family or group medical insurance plans.

Students are also urged to avoid a course-credit overload (19 or more credits). The nominal workload expectation is about 3 or 4 hours per week per credit, in addition to time spent in class. Overloading adds to demands on the student's time, and often, the result is less time spent on each course rather than more time spent on coursework overall. Adding more courses to the student's roster reduces the student's ability to focus the concentrated effort required to learn deeply. Coursework should be the student's highest priority for allocating time. Lehigh University is a rich experience with opportunities for student development on other dimensions besides academics. Indeed, students who participate in extracurricular activities and cultural events, who get involved in community activities, who maintain connections with friends and family, and who read newspapers, magazines, and for pleasure are happier, more well-rounded people who learn more and earn better grades. Having time to allocate to such leisure activities provides for much-needed rest and relaxation, lowers stress, keeps work in perspective, and engages the student in personal development beyond academics. Experience also shows, even for the very best students, overloading increases the risk of lowering the student's GPA or otherwise impeding academic progress. Finally, overloading increases the demand for resources, in particular faculty and staff effort and space in classes, which compromises the quality of the educational experience for all students and may reduce access to limited enrollment courses. For all of these reasons, Lehigh University has adopted a policy of constraining overloads.

Overload Limitations:

- 1. Overload approval will not be granted for the purpose of repeating a course.**
- 2. No overload approval will be granted in a semester where the student is enrolled in a graduate course.**
- 3. Any course(s) approved for overload cannot be added until after the end of the normal (three week) registration period. Space in a course cannot be reserved for students intending to add the course as an overload.**

Overload approval requirements vary by GPA and entry into the University. Typical loads are 12 to 18 credits. 17-18 credits is an overload for first semester students. 19 credits is an overload for all other students. Overload rules by grade point average are below:

First semester students:

- 17-18 credits, Associate Dean*
- 19 or more, SOS (Standing of Students Petition)

GPA 2.5 or below:

- 19 or more, SOS (Standing of Students Petition)

GPA between 2.5 and 3.5:

- 19 or more credits, Associate Dean*
- 20 or more, SOS (Standing of Students Petition)

GPA 3.5 or above:

- 19-20 credits, Associate Dean*
- 21 or more, SOS (Standing of Students Petition)

Undergraduates that have been approved for an overload will not be permitted to register for the overload course and credits until **after** the regular advanced registration period has ended. As a rule of thumb, this will be three weeks after the registration period begins.

If you have been informed by the appropriate University official (in most cases the Associate Dean of your college) your overload request has been approved, you will have your credit-hour maximum increased. After such time you will be able to register for the overload course. Keep in mind, having approval for an overload **does not** guarantee availability. This is on a space available basis only. Procedures for special section registration procedures and approvals remain in place.

For all students with a GPA that requires dean and advisor approval and SOS (Standing of Students Petition) approval, as noted in the chart above, a full petition to the committee must be submitted by the last day to drop/add in the Fall or Spring for the following term.

B. Other

Department Awards

The Department of Materials Science and Engineering offers the following undergraduate student awards.

Tarby Prize (Fall)

- ❖ Given to a junior for achieving the best academic performance during the first two years at Lehigh.

** The following awards are given in the **Spring Semester**. **

Bradley Stoughton Student Award

- ❖ Given to an outstanding senior in the Materials Science and Engineering Department.

Kahn Memorial Award

- ❖ Given to a senior outstanding in materials science and engineering.

Allen S. Quier Prize

- ❖ Given to the senior adjudged by the staff of materials science and engineering to have made the most progress in that curriculum.

Handwerk Prize

- ❖ Given to a senior for outstanding achievement in the fields of chemistry, materials science and engineering or earth and environmental sciences.

Gilbert Doan Award

- ❖ Given to a sophomore for outstanding performance in academics and work-study activities.

Harmer Prize

- ❖ Citizenship Award which is given to a sophomore, junior or senior.

The Department Chair's Good Samaritan Award

- ❖ Given to a student in recognition of a student going above and beyond the call of duty to assist and support the Materials Science & Engineering Dept.

DEI Champion Award

- ❖ This award is given to a graduate and undergraduate student who has demonstrated an exceptional commitment to and/or prompted DEI within the MSE Department.

Student Materials Society (SMS)

OVERVIEW

The Student Materials Society is composed of the student body in the Materials Science & Engineering Department. SMS is an organization recognized by national societies such as ASM International, TMS, and Materials Advantage.

PURPOSE

The goal of SMS is to provide a social and educational supplement to the standard academic coursework of the Materials Department.

LEADERSHIP

Four officer positions and a faculty advisor comprise the leadership of the organization. These include the President, Vice President, Treasurer and Secretary. The terms are one year with exception of the faculty advisor. Terms begin at the end of each school year, generally in the month of April. All students in junior standing are eligible for officer positions, making their term the majority of their senior year.

EVENTS

The Student Materials Society has the opportunity to plan many different types of events for the Materials Science & Engineering Department. The officers are in charge of planning events, and all the associated particulars of each event (time, location, cost, etc.) Typically these events include but are not limited to: fall barbeque, winter banquet, spring barbeque, and graduate school information sessions. As shown by the list, events can be social, educational, or anywhere in between. Depending on the event, it could be attended by people in the materials department only or by the entire student body.

FUNDING

There are various sources of funding for SMS, one of which includes a yearly allowance from the Lehigh University Student Senate. This funding must be used each year, indicating activity of the society or it will be withdrawn by the Student Senate. In addition, SMS receives a small sum for each member of both SMS and Materials Advantage/ASM/TMS (from Materials Advantage/ASM/TMS). Another source of funding includes charging for various activities and events.

Lehigh Microscopy School

In June of each year, approximately 150 people attend microscopy courses in our department during the Lehigh Microscopy School. These courses, begun in 1970 by former Professor Joe Goldstein, provide people from industry with the fundamentals and advanced techniques of scanning electron microscopy, analytical transmission electron microscopy, microanalysis, and scanning probe microscopy. In some places in the world, Lehigh University is known for offering these courses and other activities related to electron microscopy.

If you plan to be in the area at the end of May and the first week of June, there is the potential to earn a stipend helping with these courses while allowing you to hone your microscopy skills.

C. Some words of advice from the faculty “in loco parentis”

Words of Fatherly and Motherly Advice

1. Choosing HSS courses
2. Choosing Electives
3. Troubles

1. Choosing HSS courses

The range of choices for your HSS courses is enormous. How to decide which courses to select can be a daunting prospect. We would like to suggest you take the following factors into account.

First and most importantly, take courses that are interesting to *you*. Don't take courses only because you have friends taking them. Their interests may not be the same as yours. The HSS courses you take should give you pleasure.

Second, consider the impact on your career. For example, if you expect to get a job that will take you to the Middle East, consider courses in Arabic or Muslim studies.

Finally, among the rules which govern HSS is the "depth" rule. This says you must take at least 8 credits (including 3 credits at the 100 level or above) in the same department or program. You should give special thought to the subject you choose for these courses. We suggest you take a course in the subject you plan to use for your depth requirement early on. In this way, if you find you do not like the subject after all, you will still have time to find another subject.

2. Choosing Electives

In choosing the Engineering Science Electives, the Approved Elective, and the Free Electives, the way you make the choice is very similar to the way you choose HSS courses. Generally, you should choose things you find interesting and things that you expect to help in your career. These courses are taken towards the end of your studies. This should make it easier to make the choices, because you will be more familiar with the system. Please note, in the case of the Engineering Science Electives and the Approved Electives, not all of the listed courses will be available at the time you might want to take them. Among the elective courses, many may be given only every second year (or even less frequently). If there are particular courses you would like to take, it would be wise to contact the professor concerned as early as you can to be sure of its availability. You wouldn't want to plan your studies only to find that a course you were relying on will not be given.

3. Troubles

Almost all students go through difficult times. It is very common to go through weeks or months when your studies are not up to the level they could and should be. Periods of emotional problems (depression, frustration, anger, and so on) are quite normal. Many students are faced with problems unrelated to their studies: financial or family problems, for example.

All of this is normal. It is to be expected. You will be fortunate if you complete your time at Lehigh without such a period. However, most students work through these troubles and finish their studies successfully.

Our fatherly and motherly advice on this topic is this. When troubles start, do not ignore them or just wait for them to go away. As soon as you are aware of a problem, get help. The worst mistake you can make is (perhaps out of pride or embarrassment) to delay getting help. Help is available in many places and in many forms. Depending on the nature of the problem, you should talk to one of the following before the problem escalates. There is no shortage of people who can offer you assistance.

Your professor

Your advisor

Your parents

Gryphons

The Harassment Officer

The Chair or Associate Chair of the Department

Counseling & Psychological Services: (incso@lehigh.edu) Phone: 610-758-3880

Residence Life Coordinators: (inlife@lehigh.edu) Phone: 610-758-6598

The Dean of Students' Office: (indost@lehigh.edu) Phone: 610-758-4156

The Lehigh Ombuds Office:

- Anne Meltzer: (asm3@lehigh.edu) Phone: 610-758-3673
- Kathleen Hutnik: (kaha@lehigh.edu) Phone: 610-758-3648
- Jennifer Swan: (jms5@lehigh.edu) Phone: 610-758-5484

The University Chaplain: Phone: 610-758-3877

Your personal religious mentor (priest/rabbi/etc.)